

Eshteal Arak Industrial Engineering Company is the only manufacturer of high-capacity rotary cup burners in the country, and these burners are used by all boiler companies in the country. Among the unique products produced by this company are power valves that are designed for saturated and superheated steam lines. This product was produced for the first time in the country in 2014 in the Mobarake steel complex and at a pressure of 70 bar. It has been used successfully. Eshteal Arak Industrial Engineering Company has been modernizing its production lines since 2003 and is currently equipped with more than 98 machines, 61 of which are CNC lathes and milling centers (referred to at the end), stepped into the field of producing products with modern sophisticated technology. It should be mentioned that this company has succeeded in obtaining the knowledge-based badge on burners and valves during two consecutive periods, and in order to enhance the brand and satisfy customers, the necessary standards such as ISIRI 7595, ISIRI 7594, ISO 3834, ISO 9001:2015 and implemented 5S

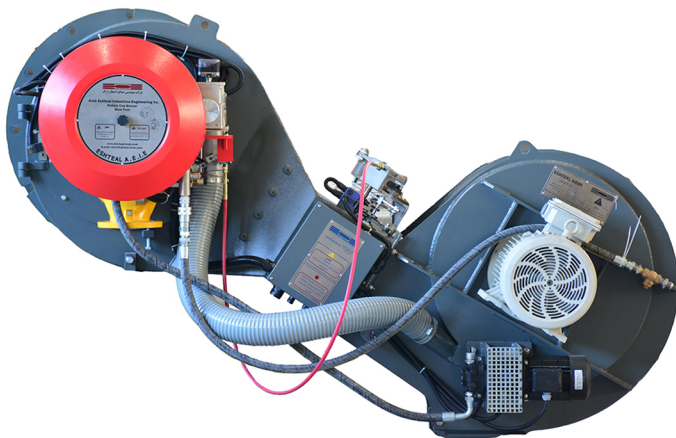

The rotary cup series covers a firing range from 3740kW through to 18200kW, and have been designed for use on hot water or industrial steam Boilers.

ERD Series Burner



ESHTEAL ARAK

INDUSTRIAL ENGINEERING CO.
Manufacturer of burners, valves
and precision tools for steam boilers

☎ 5
☎ 09908136277 (sales)
☎ 09912709038 (after sales)
📠 34131217
✉ eshteal.arak@gmail.com
✉ eshteal.commerce@gmail.com
📷 eshtealarak

📍 Factory: Hadid St-Haji Abad Industrial Zone 7th km of Qom Road-Arak-Iran
📍 Head office: 4th floor-No.3 Apartment Asef Vaziri alley southern Bahar St Taleghani St-Tehran-Iran

ERD SERIES BURNER

RANGE OVERVIEW

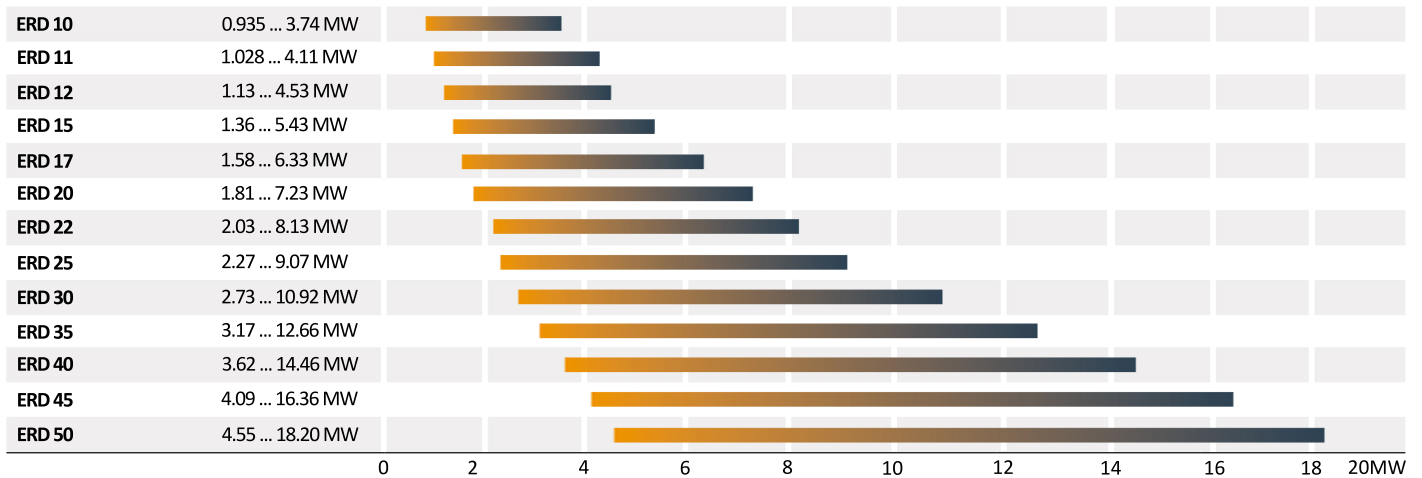

MAIN FEATURES

- Suitable for almost all combustion chamber geometries.
- In a rotary cup burner, there are separate ducts provided for primary and secondary air, this gives a well-controlled flame shape.
- Low fuel supply pressure required.
- High efficiency, low maintenance costs and long service life.
- turndown of 4:1.
- Constant velocity design wind box for improved air distribution and performance over entire turn-down range.
- Designed in accordance with the European Standard EN 676 and EN267 and approved in accordance with the Iranian Standard ISIRI 7594 and ISIRI 7595.
- Emission class: Low NOx class 2 (≤ 120 mg/kWh).

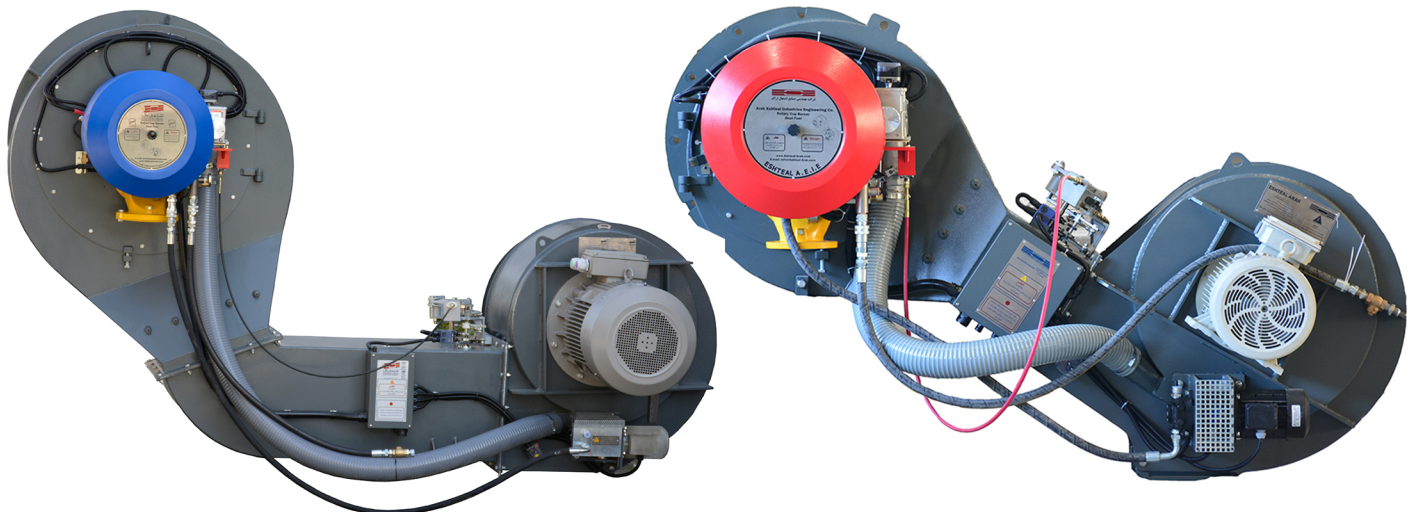

Dimensions (approx .) in mm

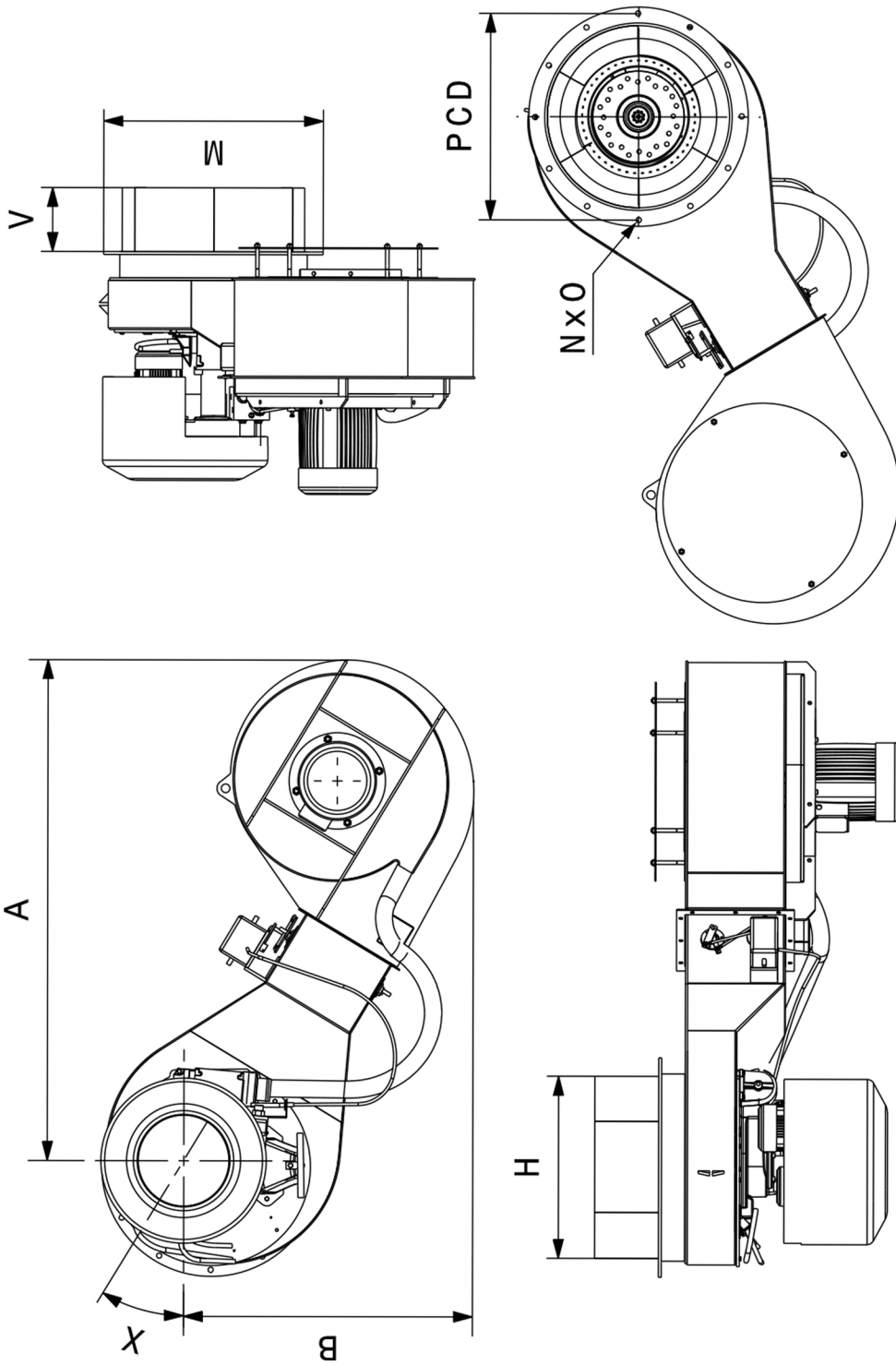

BURNER MODEL	A	B	H	M	V	X	N	O	PCD
ERD-PRD 5-12	1700	1150	635	765	224	40	12	19	720
ERD-PRD 14-20	2000	1080	735	865	256	32	12	19	814
ERD-PRD 22-30	2200	1150	862	992	218	32	12	19	941
ERD-PRD 35-50	2400	1300	1080	1210	403	32	18	19	1144
	2550	1350				37			